

DIST and HGT in M

PRECISION APPROACH TERRAIN CHART - ICAO

OULU AERODROME, FINLAND RWY 12

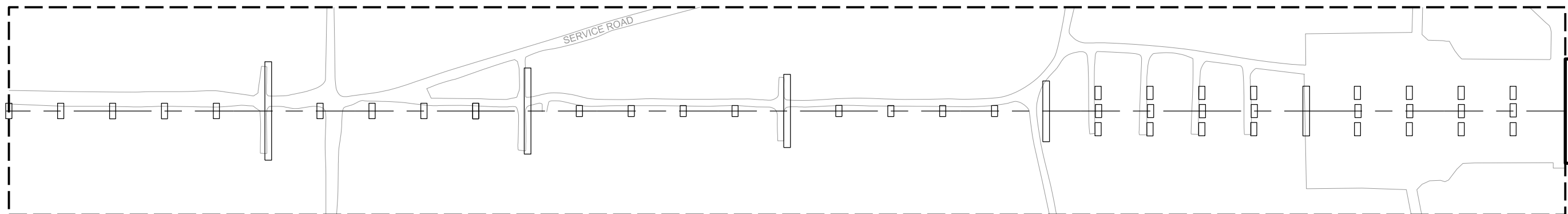

12

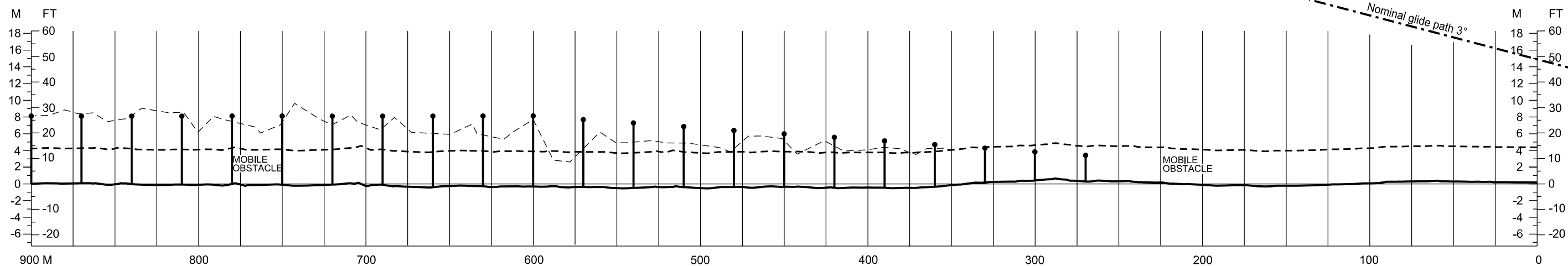

LEGEND

APPROACH LIGHTS	
BUILDING OR LARGE STRUCTURE	
CONTOUR	
CENTRE-LINE PROFILE	
DEVIATION AT LEAST 3 M FROM CENTRE-LINE PROFILE	

HORIZONTAL SCALE 1:2500
VERTICAL SCALE 1:500

Contours and HGT are related to ELEV of RWY 12

CHG: new OBST data